

REVISION HISTORY			
REV	DESCRIPTION	DATE	BY
A	RELEASED	10/11/2007	AJS

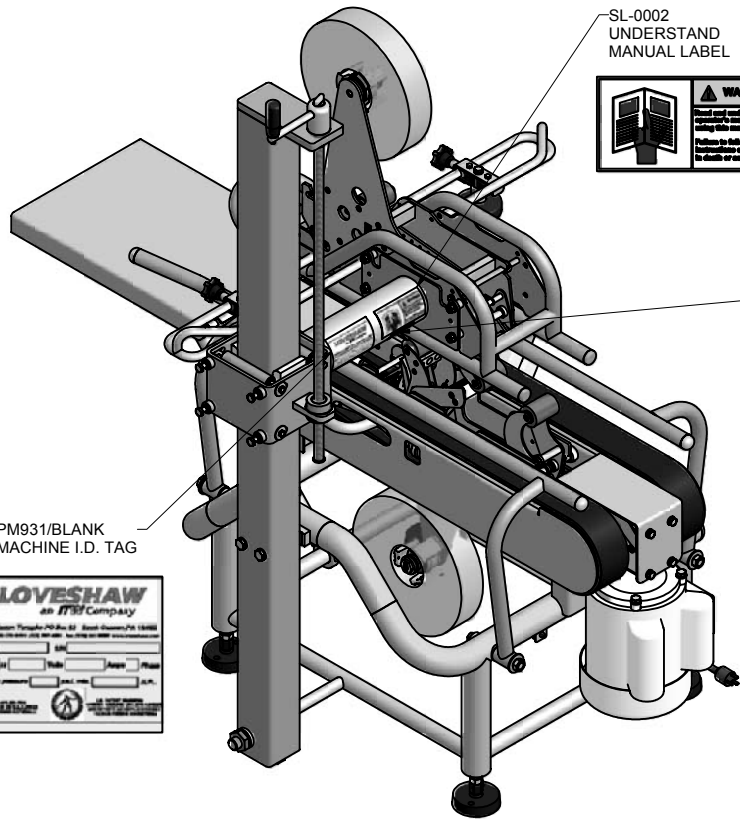

SL-0002
UNDERSTAND
MANUAL LABEL



SL-0022 or SL-0022/2
INSPECTED BY LABEL

**INSPECTED
BY NO.**



SL-0001
BLADE HAZARD
LABEL

PM931/BLANK
MACHINE I.D. TAG



SL-0004
PINCH POINT
ROLLER LABEL



SL-0006
ENTANGLEMENT
HAZARD LABEL



SL-0028
MACHINE LABEL

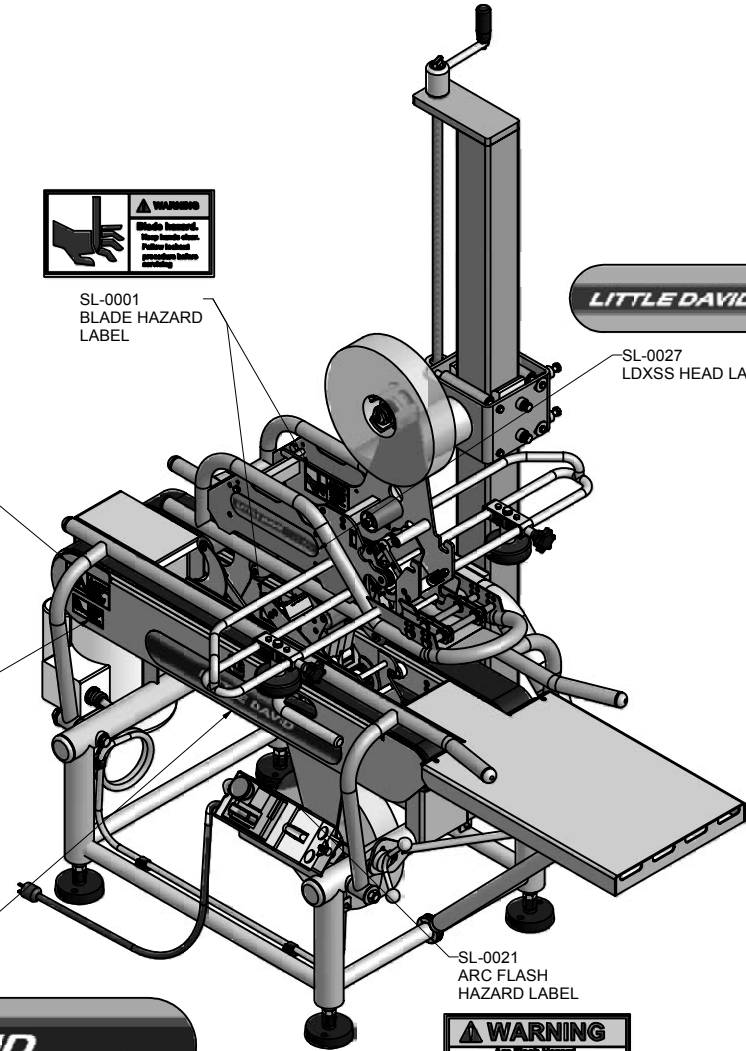

SL-0027
LDXSS HEAD LABEL



SL-0021
ARC FLASH
HAZARD LABEL

MATL	PART #	CAD FILE	G821931-SAFE LABEL	UNLESS OTHERWISE NOTED:	LOVESHAW an itw Company RT. 296, SOUTH CANAAN, PA.
NOTED	STD	PLOT DATE	10/12/2007	OTHERWISE NOTED:	TITLE
ST. ST.	N/A	DRAWN DATE	10/11/2007	X ±.050 INCH .XX ±.015 .XXX ±.005	LDXSS MACHINE LABELS
STAINLESS : NO FINISH		DO NOT SCALE PRINT		ANGLES ±.1° X ±1.0mm MACH. FINISH ✓ METRIC .XX ±.3mm .XXX ±.1mm	DWG NO. MAIN ASSY LDSS33 WR SAFETY LABELS
THIS DRAWING AND SUBJECT MATTER THEREON IS THE EXCLUSIVE PROPERTY OF LOVESHAW/ITW AND IS TO BE TREATED BY YOU AS CONFIDENTIAL PROPRIETARY INFORMATION. THIS DRAWING OR SUBJECT MATTER THEREOF SHALL NOT BE REPRODUCED OTHER THAN FOR YOUR OWN USE OR TO BE DISCLOSED TO OTHER WITHOUT THE EXPRESSED WRITTEN CONSENT OF LOVESHAW/ITW AND WILL BE RETURNED TO LOVESHAW/ITW UPON REQUEST.					SCALE N/A
FRACTIONS ± 1/64			MATERIAL	NOTED	CHECKED
			DRAWN	TONYS	APPROVED

MACHINE SPECIFICATIONS

MACHINE DIMENSIONS:

HEIGHT:	58.4 inches	1483.4 mm
WIDTH:	38 inches	965.2 mm
LENGTH:	56 inches	1422.4 mm (with front pack table)

TABLE HEIGHT (adjustable):

MINIMUM:	22.5 inches	571.5 mm
MAXIMUM:	28.5 inches	723.9 mm

ELECTRICAL:

STANDARD:	115V/1/60 240V/1/50
OPTIONAL:	220V/1/50,60 220V/3/50,60 380V/3/50 440V/3/50 440V/3/60

BOX CAPACITY:

LENGTH:	4.5 inches to unlimited max.	114.3 mm to unlimited max.
WIDTH:	5.5 inches to 27 inches	139.7 mm to 685.8 mm
HEIGHT:	4.5 inches to 24 inches	114.3 mm to 609.6 mm

OPERATING SPEED:

BELT SPEED:	80 ft / min.	18 m/min.
NUMBER OF BOXES/MIN.:	VARIES WITH BOX SIZE	

CLOSURE MATERIAL - PRESSURE SENSITIVE TAPE

WIDTH:	1.5 inches to 2 inches	38 mm to 50 mm
MAX. ROLL DIAMETER:	15 inches	380 mm
WEIGHT: (uncrated)	180 lbs.	81 kg.